

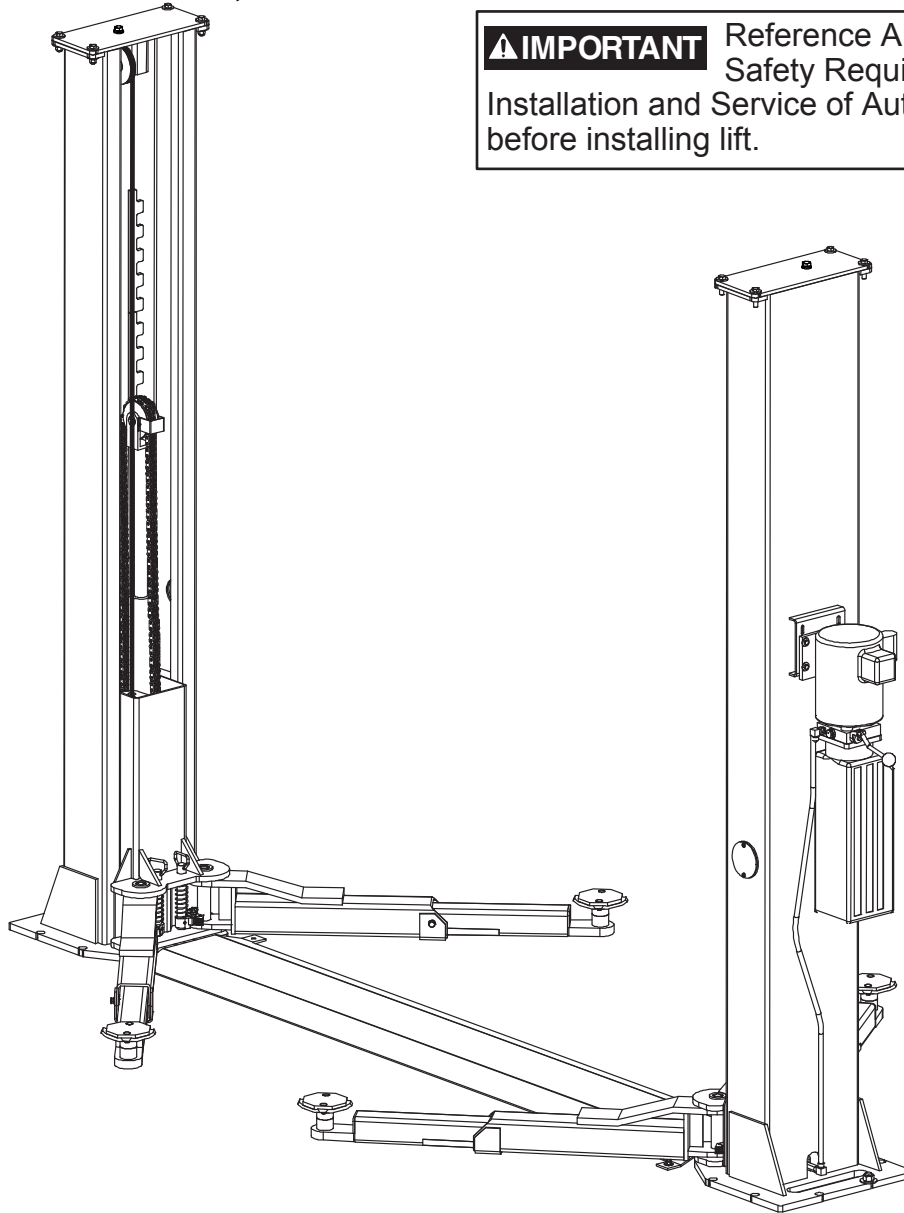

# Pro9F

## Floor Plate Automotive Lift 9,000 POUND CAPACITY

**⚠ IMPORTANT** Reference ANSI/ALI ALIS, Safety Requirements for Installation and Service of Automotive Lifts before installing lift.



# INSTALLATION / OWNERS MANUALS

Read this manual thoroughly before installing, operating, or maintaining this lift. When done with installation, be sure to return documents to package and give all materials to lift owner/operator. When installation is complete, be sure to run lift up and down a few cycles with and without “typical” vehicle loaded on lift.

# TABLE OF CONTENTS

• IMPORTANT INFORMATION.....	2
• GENERAL LIFT INFORMATION / FEATURES.....	3
• LIFT SPECIFICATIONS:.....	4
• LIFT AREA LAYOUT INFORMATION.....	5
• FOUNDATION and ANCHORING REQUIREMENTS .....	6
• TOOLS and EQUIPMENT REQUIRED for INSTALL .....	7
• INSTALLATION PROCEDURE .....	8
• OWNER / EMPLOYER RESPONSIBILITIES .....	14
• LIFT LOCKOUT/TAGOUT .....	14
• SAFETY PROCEDURES .....	15
• LIFT OPERATION.....	18
• PREVENTIVE MAINTENANCE SCHEDULE .....	19
• TROUBLESHOOTING .....	21
• ILLUSTRATED PARTS BREAKDOWN .....	23
• PARTS LIST.....	28

## IMPORTANT INFORMATION

### Two Post Lifts

1. Any freight damage must be noted on the freight bill before signing and reported to the freight carrier with a freight claim established. Identify the components and check for shortages. If shortages are discovered, please contact the Distributor / Sales Rep. in your area for service.
2. Consult building owner and / or architect's plans when applicable to establish the best lift location. The lift should be located on a relatively level floor with 4 in. minimum thickness, 3000-psi concrete slab that has been properly cured. **There can be no cracks in the slab within 36 in. of the base plate location, and no seams in the foundation within 6 in. of its location! Remember: any structure is only as strong as the foundation on which it is located!**

**IMPORTANT! Make sure you have extra help or heavy duty lifting equipment when unloading and assembling the lift.**

3. Please read the safety procedures and operating instructions in this manual before operating lift. Keep this manual near lift at all times. Make sure all operators read this manual.
4. The lift should be located on a relatively level floor of less than 3 degrees slope. If slope is questionable, consider a survey of the site and/or the possibility of pouring a new level concrete slab.
5. Make sure you have enough area and ceiling height to install lift. (See Lift Specifications)
6. Never raise a car until you have double checked all bolts, nuts and hose fittings.
7. Always lower the lift onto the locks before going under the vehicle. Never allow anyone to go under the lift when raising or lowering.

**This is a vehicle lift installation/operation manual and no attempt is made or implied herein to instruct the user in lifting methods particular to an individual application. Rather, the contents of this manual are intended as a basis for operation and maintenance of the unit as it stands alone or as it is intended and anticipated to be used in conjunction with other equipment.**

**Proper application of the equipment described herein is limited to the parameters detailed in the specifications and the uses set forth in the descriptive passages. Any other proposed application of this equipment should be documented and submitted in writing to the factory for examination. The user assumes full responsibility for any equipment damage, personal injury, or alteration of the equipment described in this manual or any subsequent damages.**

## **CAUTION!!**

ENSURE THAT ALL CABLE SHEAVES, BEARINGS, AND SHAFTS ARE SUFFICIENTLY LUBRICATED. ALSO, THE CORNERS OF EACH COLUMN SHOULD BE LIGHTLY GREASED WITH QUALITY LITHIUM GREASE PRIOR TO OPERATING THE LIFT. LUBRICATE ALL ON AN ANNUAL BASIS.

Motors and all electrical components are not sealed against the weather and moisture. Install this lift in a protected indoor location. Failure by the owner to provide the recommended shelter could result in unsatisfactory lift performance, property damage, or personal injury.

## **GENERAL LIFT INFORMATION and FEATURES**

### **FLOOR PLATE MODEL**

The following lift is a 2-Column Hydraulic, leaf chain driven unit.

The name/model numbers are designated below:

- **Floor Plate**: Pro9F 2-Column Lift, Floor Plate Lift type, 9000 lbs. Capacity, Symmetric Swing Arm set up.

This lift is an 9,000 lb. capacity, 2-Post Lift. The locking latch system is very similar to an extension ladder. The locking latch is in contact with the latch rack. As the lift rises the locking latch drops into place. The locking latch engages the latch rack in 3" increments starting at about 16" from the ground. The locking latches must be manually disengaged for the lift to lower. The locking latch is released by pulling the Release Cable, first raising the lift to get the latch up off the latch rack. Once the raise button is pressed, the latch will automatically reengage after approximately 3" of travel. Heavy bearings and heavy-duty leaf chains are used throughout the lift. The work is done with the heavy-duty chain connected to a 2-1/2" cylinder, driven by an electric / hydraulic pump.

# LIFT SPECIFICATIONS

<b>Capacity</b>	<b>9,000 lbs. (2,250 lbs per Arm)</b>
<b>Overall Height</b>	<b>111-1/4"</b>
<b>Overall Floor Width</b>	<b>138-1/2"</b>
<b>Maximum Lift Height</b>	<b>81"</b>
<b>Minimum Adapter Height</b>	<b>4"</b>
<b>Between Columns</b>	<b>111"</b>
<b>Drive Thru</b>	<b>97-1/4"</b>
<b>Motor</b>	<b>2HP, 208 - 230 VAC, 1PH</b>

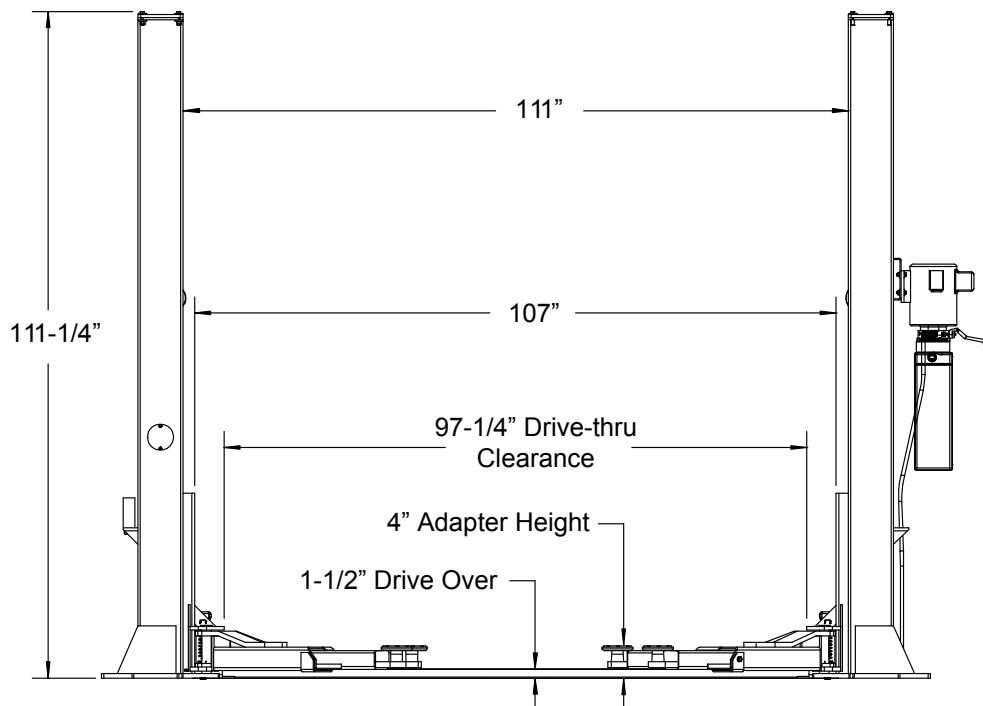
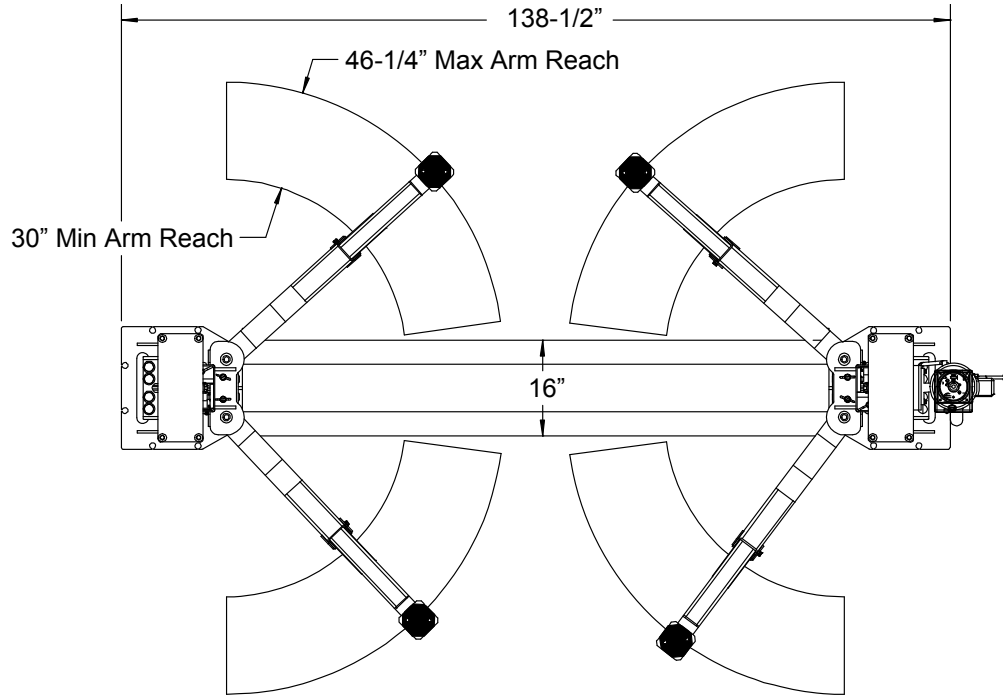

# LIFT AREA LAYOUT INFORMATION

(Symmetrical Arm configuration)

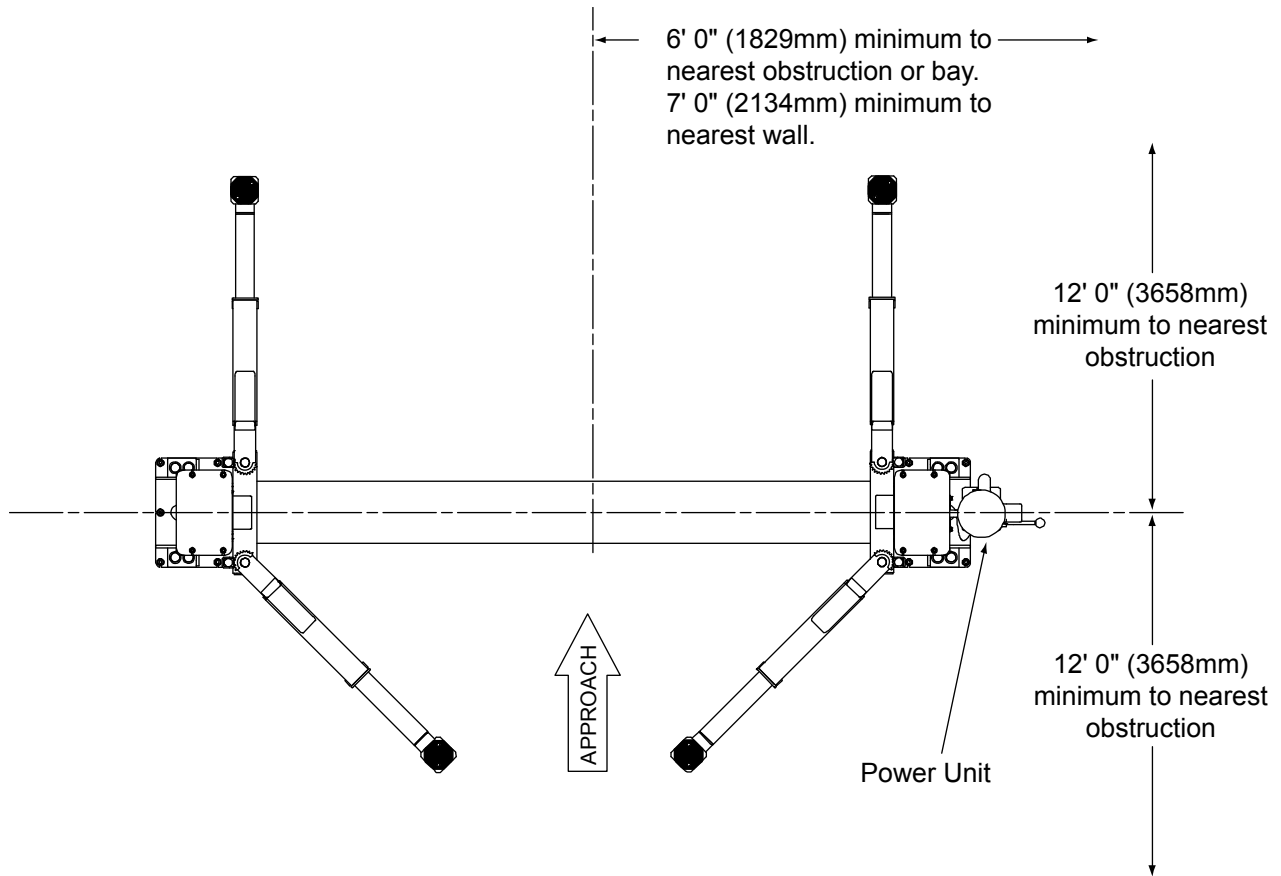

**NOTE: Lift can be installed so power unit can column can be located on either side. However, to save operation steps it is recommended that it is placed on passenger side of lift.**

# FOUNDATION and ANCHORING REQUIREMENTS

1. Concrete shall have compression strength of at least 3,000 PSI and a minimum thickness of 4" in order to achieve a minimum anchor embedment of 3 1/4". NOTE: When using the standard supplied 3/4" x 5 1/2" long anchors, if the top of the anchor exceeds 2 1/4" above the floor grade, you DO NOT have enough embedment.
2. Maintain a 6" minimum distance from any slab edge or seam. Hole to hole spacing should be a minimum 6 1/2" in any direction. Hole depth should be a minimum of 4".

## **CAUTION!!**

3. DO NOT install on asphalt or other similar unstable surface. Columns are supported only by anchoring to floor.
4. Using the horseshoe shims provided, shim each column base as required until each column is plumb. If one column has to be elevated to match the plane of the other column, full size base shim plates should be used. Torque anchors to 150 ft-lbs. Shim thickness MUST NOT exceed 1/2" when using the 5 1/2" long anchors provided with the lift. Adjust the column extensions plumb.
5. If anchors do not tighten to 150 ft-lbs. installation torque, replace the concrete under each column base with a 4' x 4' x 6" thick 3,000 PSI minimum concrete pad keyed under and flush with the top of existing floor. Allow concrete to cure before installing lifts and anchors (typically 2 to 3 weeks).

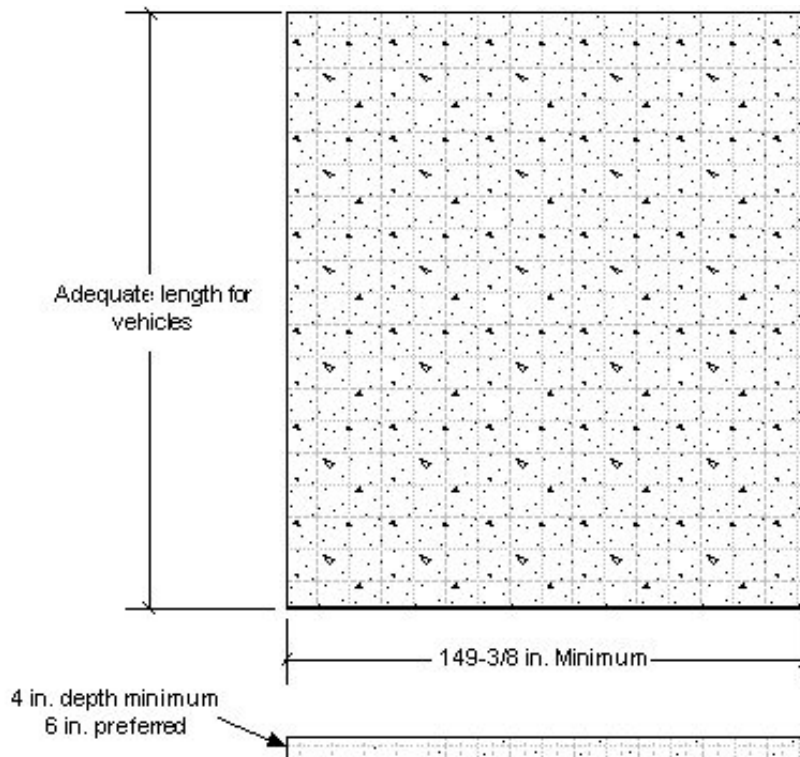

# **TOOLS & EQUIPMENT REQUIRED FOR INSTALL**

The installation of this lift is relatively simple and can be accomplished by two men in a few hours. The following tools and equipment are needed:

- Hoist or Forklift (optional)
- Two 10' to 12' step ladders
- ISO 32 Light Hydraulic Oil (approx. 12 quarts)
- Tape Measure
- Rotary Hammer Drill with 3/4" and 3/8" Drill Bit (Core Drill Rebar Cutter recommended)
- 4' Level
- Metric Sockets and Open Wrench set
- Vise grips
- 8mm Socket Head Wrench
- Torque wrench with 1-1/8" socket for anchors
- Teflon Tape

# INSTALLATION PROCEDURE

**STEP 1:** After unloading the lift, place it near the intended installation location.

**STEP 2:** Remove the shipping bands and packing materials from the unit. The Power Unit will be unpacked from the top. Note: Be careful not to drop power unit.

**STEP 3:** Remove the packing brackets and bolts holding the two columns together (do not discard bolts; they are used in the assembly of the lift).

**STEP 4:** Once the power unit column location is decided, insure that the proper lift placement is observed from walls and obstacles. Also check the ceiling height for clearance in this location. **Note:** the power unit column can be located on either side. It is helpful to try and locate the power side with the passenger side of the vehicle when loaded on the lift to save steps during operation.

**STEP 5:** Install the top plate onto the top of the columns. **NOTE:** 1" = 25.4mm

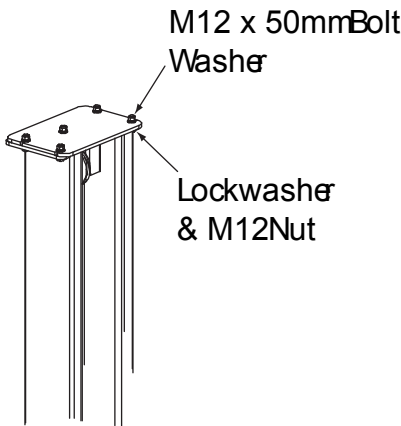

**STEP 6:** Position the columns facing each other **138-1/2"** outside base plates. Square the columns by measuring diagonally from corner points on base plates (within 1/4"). See plan and elevation drawings on page 4 for detailed drawing.

**STEP 7:** Use the existing holes in column base plate as a guide for drilling the 3/4" diameter holes into the concrete. Drill the anchor holes, installing anchors as you go. Verify drive over plate will fit between column baseplates before anchoring second column.

**NOTE:** Drilling thru concrete slab (recommended) will allow the anchor to be driven thru the bottom of slab, if the threads are damaged or if the lift will need to be relocated.

**CAUTION!!**

**Anchors must be at least 6" from the edge of the slab or any seam.**

1. Use a concrete hammer drill with a carbide tip, solid drill bit the same diameter as the anchor, 3/4". (.775 to .787 inches diameter). Do not use excessively worn bits or bits which have been incorrectly sharpened.



2. Keep the drill in a perpendicular line while drilling.
3. Let the drill do the work. Do not apply excessive pressure. Lift the drill up and down occasionally to remove residue to reduce binding.
4. Drill the hole to depth equal to the length of anchor. **Note:** Drilling thru concrete (recommended) will allow the anchor to be driven thru the bottom of foundation if the threads are damaged or if the lift will need to be relocated.
5. For better holding power blow dust from the hole.

Place a flat washer and hex nut over threaded end of anchor, leaving approximately 1/2" of thread exposed carefully tap anchor. Do not damage threads. Tap anchor into the concrete until nut and flat washer are against base plate. **Do not use an impact wrench to tighten!** Tighten the nut, two or three turns on average concrete (28-day cure). If the concrete is very hard only one or two turns may be required. Check each anchor bolt with torque wrench set to 150 foot pounds.

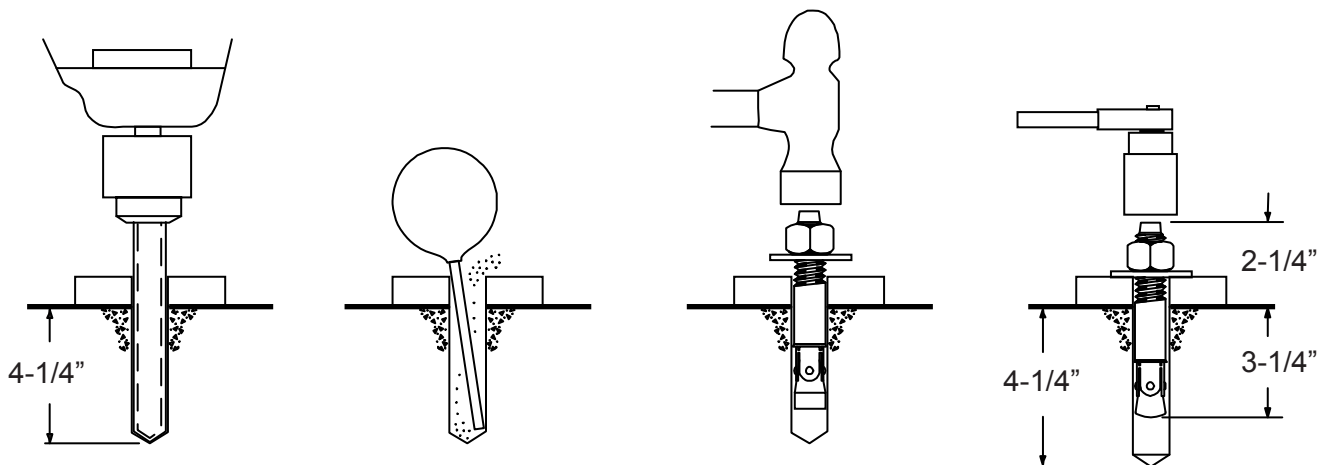

Drill holes using 3/4" carbide tipped masonry drill bit per ANSI standard B94.12.1977

Clean hole.

Run nut down just below impact section of bolt. Drive anchor into hole until nut and washer contact base.

Tighten nut with Torque wrench to 150 ft.-lbs.

**STEP 8:** Using a level, check column for side-to-side plumb and front-to-back plumb. If needed, use horseshoe shims provided by placing shims underneath the base plate and around the anchor bolt. This will prevent bending the column bottom plates (Shim thickness should not exceed 1/2"). Tighten 3/4" anchor bolts to **150 ft.-lbs.** of torque.

**STEP 9:** Set carriages on the first safety latch engagement. Be sure each carriage is at the same height by measuring from the top of the base to the bottom of the carriage (double check the latches before working under the carriages). This dimension should be within 1/4".

**STEP 10: Installing the equalizing cables:** (see diagram below) Loosen the two Cable Retaining Bolts as shown. Route the first cable as shown. Tighten nut on one cable stud so that the end of stud passes the nylon on the nut. Pull the other end of cable and run nut on it. Repeat above for second cable. Once installed tighten the Cable Retaining Bolts.

**NOTE: DO NOT tighten cables at this time. Just start them on the threads.**

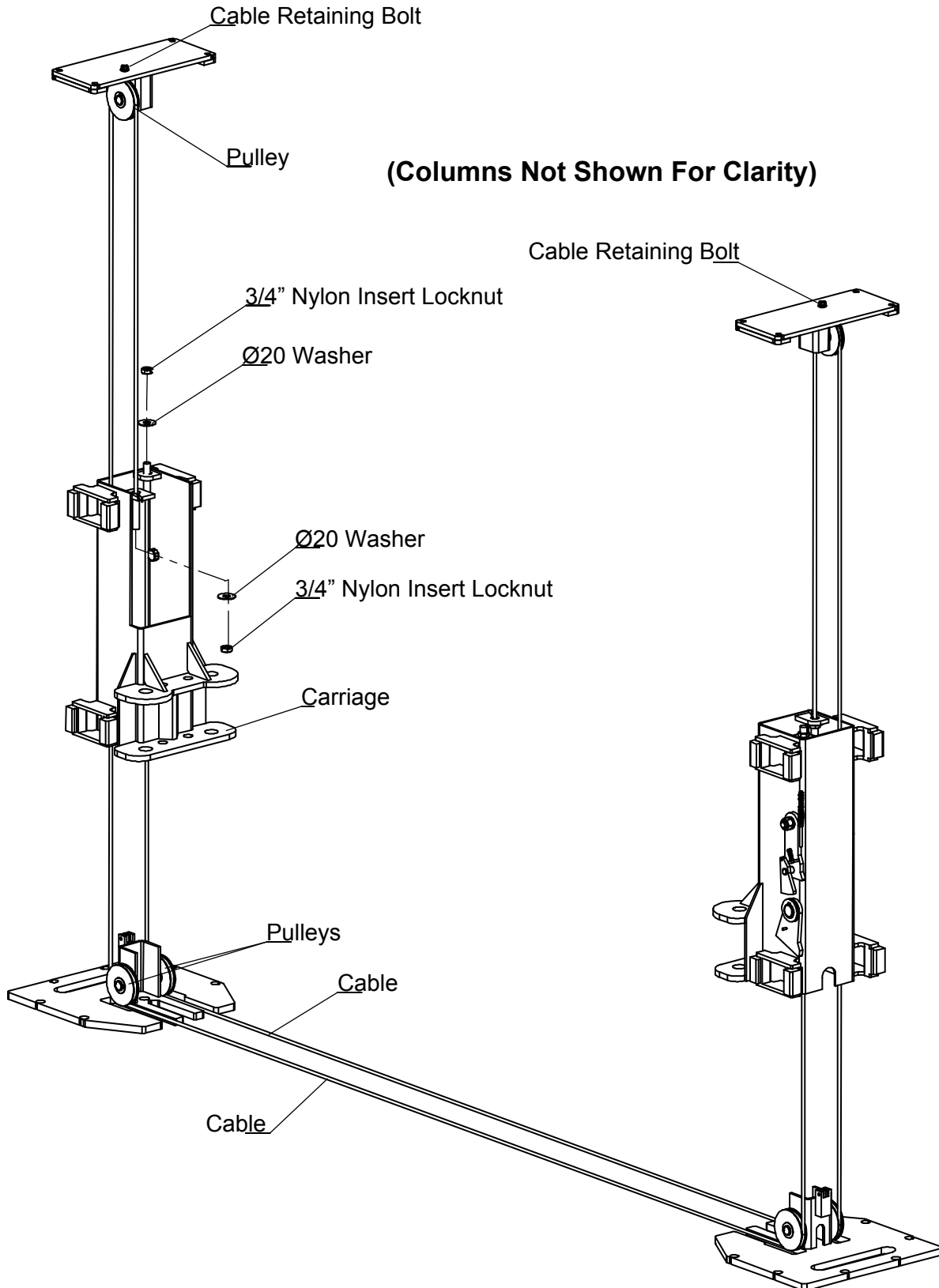

**STEP 11:** Cylinder centering and chain installation: Make sure the “Tip” on the bottom of the cylinder is properly located into the center hole on top of the cylinder mount in base.

**STEP 12:** Connect the Hydraulic Hoses and Fittings, as shown.

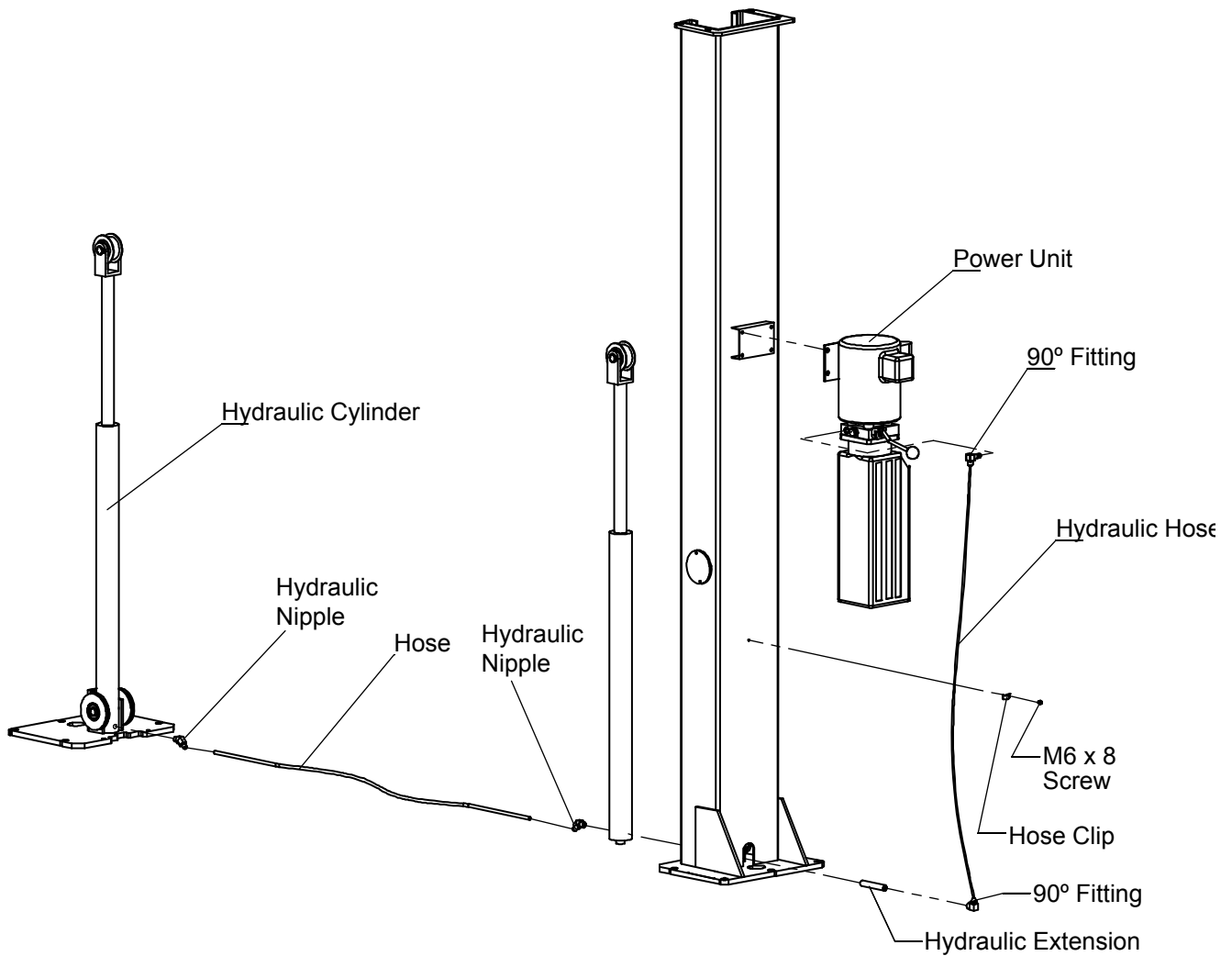

**STEP 13:** Mount the Power Unit on lift as shown.

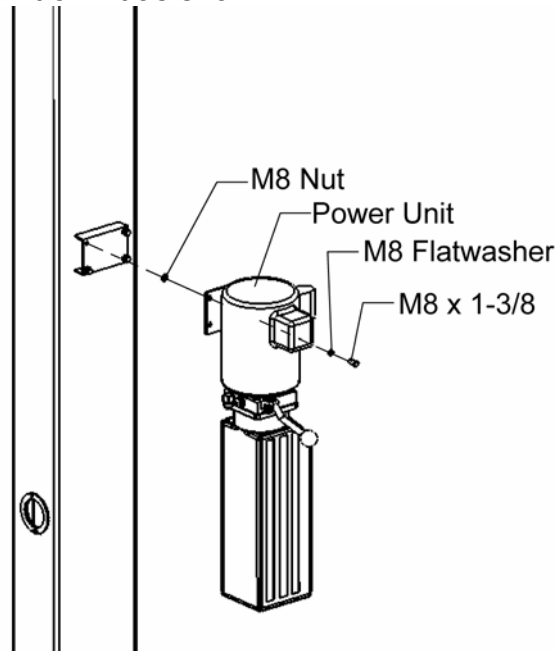

**STEP 14:** Mount the Floor Plate as shown below. Drill 3/8" holes using holes in plate as guides. Following drill steps/directions used when anchoring columns. Tighten to 25 ft-lbs.

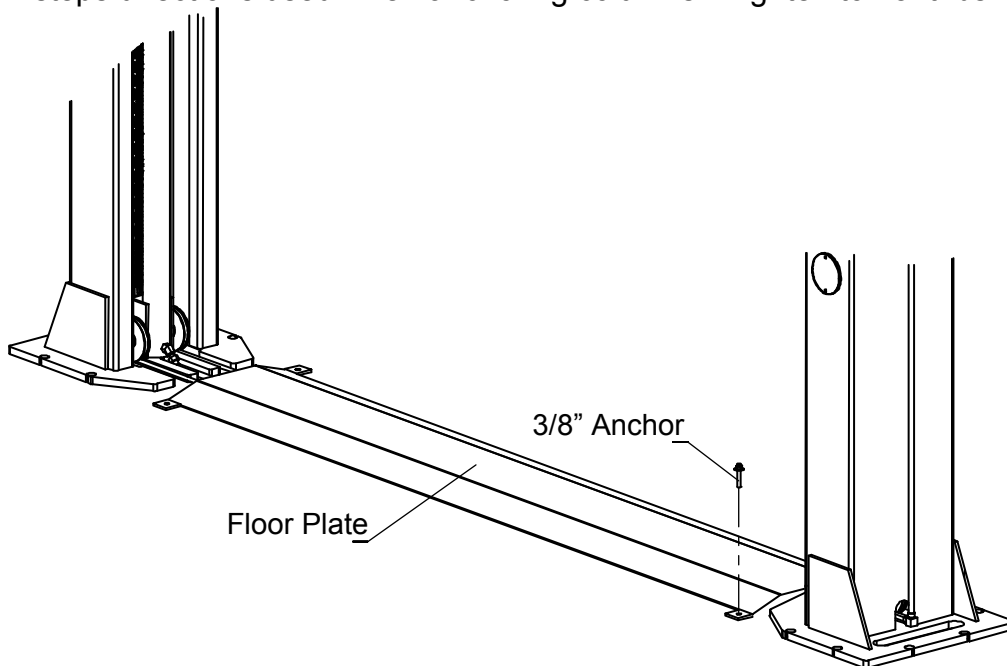

**STEP 15:** Install the swing arms on the carriages using the included 1-1/2" diameter pins. Check for proper engagement of the arm lock – the teeth on the lock should fully engage the gear on the arm. Note, if arm pins are not fitting, you will need to pull up on arm lock to allow slack for the arm to move around in the carriage, allowing the arm pin to fit easier.

**STEP 16:** Adjust the carriage cables tension. Adjust each cable to approximately 1/2" side-to-side play. Check the latch releases to insure the carriage is still sitting on the appropriate latch.

**STEP 17:** Remove the vented fill cap from the power unit and fill the reservoir. Use a Ten Weight (ISO AW32) non-foaming, non-detergent hydraulic fluid (i.e. Texaco HD32 or equal). The unit will hold approximately twelve quarts of fluid. If a replacement fill cap is required order from your distributor, a vented cap **MUST** be used.

**STEP 18:** Make the Electrical hookup to the power unit; 220V Single Phase. It is recommended that a 220 Volt, 30 Amp twist lock plug be installed in the power line just ahead of the power unit. Use wire capable of supporting a 30-amp circuit.

**Warning:** – the wiring must comply with local code. Have a certified electrician make the electrical hook-up to the power unit. Protect each circuit with time delay fuse or circuit breaker; 208v-230v single phase 60 Hz 30 amp.

**STEP 19:** Do not place any vehicle on the lift at this time. Cycle the lift up and down several times to insure latches click together and all air is removed from the system. To lower the lift, both latch releases must be manually released. Latches will automatically reset once the lift ascends approximately 17” from base. If latches click out of sync, tighten the cable on the one that clicks first.

**STEP 20:** With lift fully lowered, recheck power unit fluid level. Fill as required.

## **OWNER / EMPLOYER RESPONSIBILITIES**

## The Owner / Employer:

- Shall ensure that lift operators are qualified and that they are trained in the safe use and operation of the lift using the manufacturer's operating instructions; ALI/SM01-1, *ALI Lifting it Right* safety manual; ALI/ST-90 *ALI Safety Tips* card; ANSI/ALI ALOIM-2000, *American National Standard for Automotive Lifts-Safety Requirements for Operation, Inspection and Maintenance*; ALI/WL Series, *ALI Uniform Warning Label Decals/Placards*; and in the case of frame engaging lifts, ALI/LP-GUIDE, *Vehicle Lifting Points/Quick Reference Guide for Frame Engaging Lifts*.
- Shall establish procedures to periodically inspect the lift in accordance with the lift manufacturer's instructions or ANSI/ALI ALOIM-2008, *American National Standard for Automotive Lifts-Safety Requirements for Operation, Inspection and Maintenance*; and The Employer Shall ensure that lift inspectors are qualified and that they are adequately trained in the inspection of the lift.
- Shall establish procedures to periodically maintain the lift in accordance with the lift manufacturer's instructions or ANSI/ALI ALOIM-2008, *American National Standard for Automotive Lifts-Safety Requirements for Operation, Inspection and Maintenance*; and The Employer Shall ensure that lift maintenance personnel are qualified and that they are adequately trained in the maintenance of the lift.
- Shall maintain the periodic inspection and maintenance records recommended by the manufacturer or ANSI/ALI ALOIM-2008, *American National Standard for Automotive Lifts-Safety Requirements for Operation, Inspection and Maintenance*.
- Shall display the lift manufacturer's operating instructions; ALI/SM 93-1, *ALI Lifting it Right* safety manual; ALI/ST-90 *ALI Safety Tips* card; ANSI/ALI ALOIM-2008, *American National Standard for Automotive Lifts-Safety Requirements for Operation, Inspection and Maintenance*; and in the case of frame engaging lifts, ALI/LP-GUIDE, *Vehicle Lifting Points/Quick Reference Guide for Frame Engaging Lifts*; in a conspicuous location in the lift area convenient to the operator.
- Shall not modify the lift in any manner without the prior written consent of the manufacturer.
- Shall provide necessary lockout/tagout means for energy sources per ANSI Z244.1-1982 (R1993), *Safety Requirements for the Lockout/Tagout of Energy Sources*, before beginning any lift repairs.

## Lift Lockout/Tagout Procedure

### Purpose

This procedure establishes the minimum requirements for the lockout of energy that could cause injury to personnel by the operation of lifts in need of repair or being serviced. All employees shall comply with this procedure.

### Responsibility

The responsibility for assuring that this procedure is followed is binding upon all employees and service personnel from outside service companies (i.e., Authorized Installers, contractors, etc.). All employees shall be instructed in the safety significance of the lockout procedure by the facility owner/manager. Each new or transferred employee along with visiting outside service personnel, shall be instructed by the owner/manager (or assigned designee) in the purpose and use of the lockout procedure.

### Preparation

Employees authorized to perform lockout shall ensure that the appropriate energy isolating device (i.e., circuit breaker, fuse, disconnect, etc.) is identified for the lift being locked out. Other such devices for other equipment may be located in close proximity of the appropriate energy isolating device. If the identity of the device is in question, see the shop supervisor for resolution. Assure that proper authorization is received prior to performing the lockout procedure.

### **Sequence of Lockout Procedure**

- 1) Notify all affected employees that a lockout is being performed and the reason for it.
- 2) Unload the subject lift. Shut it down and assure the disconnect switch is "OFF" if one is provided on the lift.
- 3) The authorized lockout person operates the main energy isolation device removing power to the subject lift.
  - If this is a lockable device, the authorized lockout person places the assigned padlock on the device to prevent its unintentional reactivation. An appropriate tag is applied stating the person's name, at least 3" x 6" in size, an easily noticeable color, and states not to operate device or remove tag.
  - If this device is a non-lockable circuit breaker or fuse, replace with a "dummy" device and tag it appropriately as mentioned above.
- 4) Attempt to operate lift to assure the lockout is working. Be sure to return any switches to the "OFF" position.
- 5) The equipment is now locked out and ready for the required maintenance or service.

### **Restoring Equipment to Service**

- 1) Assure the work on the lift is complete and the area is clear of tools, vehicles, and personnel.
- 2) At this point, the authorized person can remove the lock (or dummy circuit breaker or fuse) & tag and activate the energy isolating device so that the lift may again be placed into operation.

### **Rules for Using Lockout Procedure**

Use the Lockout Procedure whenever the lift is being repaired or serviced, waiting for repair when current operation could cause possible injury to personnel, or for any other situation when unintentional operation could injure personnel. No attempt shall be made to operate the lift when the energy isolating device is locked out.

### **Operating Conditions**

**Lift is not intended for outdoor use and has an operating ambient temperature range of 41°-104°F (5°-40°C).**

## **SAFETY PROCEDURES**

- Never allow unauthorized persons to operate lift. Thoroughly train new employees in the use and care of lift.
- Caution - the power unit operates at high pressure.
- Remove passengers before raising vehicle.
- Prohibit unauthorized persons from being in shop area while lift is in use.
- Total lift capacity is 9,000 lbs. @ 2,250 lbs per lifting pad. Do not exceed maximum weight capacity of lift.
- Prior to lifting vehicle, walk around the lift and check for any objects that might interfere with the operation of lift and safety latches; tools, air hoses, shop equipment.

- When approaching the lift with a vehicle, make sure to center the vehicle between the columns so that the tires will clear the swing arms easily. Slowly drive the vehicle between the columns. It is recommended to have someone outside the vehicle guide the driver.
- Always lift vehicle using all four pads.
- Never use lift to raise one end or side of vehicle.
- Always raise vehicle about 3" and check stability by rocking vehicle.
- Prior to lowering vehicle, walk around the lift and check for any objects that might interfere with the operation of lift and safety latches; tools, air hoses, shop equipment.
- Always lower lift to the lock position before going under vehicle. Never allow anyone to go under the lift when raising or lowering.

### **IMPORTANT SAFETY INSTRUCTIONS**







When using your garage equipment, basic safety precautions should always be followed, including the following:

1. Read all instructions
2. Care must be taken as burns can occur from touching hot parts.
3. Do not operate equipment with a damaged cord or if the equipment has been dropped or damaged - until it has been examined by a qualified service person.
4. Do not let a cord hang over the edge of the table, bench, or counter or come in contact with hot manifolds or moving fan blades.
5. If an extension cord is necessary, a cord with a current rating equal to or more than that of the equipment should be used. Cords rated for less current than the equipment may overheat.
6. Always unplug equipment from electrical outlet when not in use. Never use the cord to pull the plug from the outlet. Grasp plug and pull to disconnect.
7. Let equipment cool completely before putting away. Loop cord loosely around equipment when storing.
8. To reduce the risk of fire, do not operate equipment in the vicinity of open containers of flammable liquids (gasoline).
9. Adequate ventilation should be provided when working on operating internal combustion engines.
10. Keep hair, loose clothing, fingers, and all parts of body away from moving parts.
11. To reduce the risk of electric shock, do not use on wet surfaces or expose to rain.
12. Use only as described in this manual. Use only manufacturer's recommended attachments.
13. ALWAYS WEAR SAFETY GLASSES. Everyday eyeglasses only have impact resistant lenses, they are not safety glasses.

### **SAVE THESE INSTRUCTIONS**

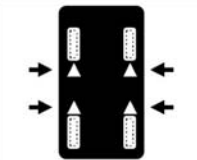

<b>SAFETY INSTRUCTIONS</b>	<b>SAFETY INSTRUCTIONS</b>
	
Read operating and safety manuals before using lift.	Proper maintenance and inspection is necessary for safe operation.
<b>SAFETY INSTRUCTIONS</b>	The messages and pictographs shown are generic in nature and are meant to generally represent hazards common to all automotive lifts regardless of specific style.
	Funding for the development and validation of these labels was provided by the Automotive Lift Institute, PO Box 33116 Indialantic, FL 32903-3116.
Do not operate a damaged lift.	They are protected by copyright. Set of labels may be obtained from ALI or its member companies.
©	© 1992 by ALI, Inc. ALIWL101s

<b>CAUTION</b>	<b>CAUTION</b>
	
Lift to be used by trained operator only.	Authorized personnel only in lift area.
<b>CAUTION</b>	<b>CAUTION</b>
	
Use vehicle manufacturer's lift points.	Always use safety stands when removing or installing heavy components.
<b>CAUTION</b>	<b>CAUTION</b>
	
Use height extenders when necessary to ensure good contact.	Auxiliary adapters may reduce load capacity.
The messages and pictographs shown are generic in nature and are meant to generally represent hazards common to all automotive lifts regardless of specific style.	
Funding for the development and validation of these labels was provided by the Automotive Lift Institute, PO Box 33116 Indialantic, FL 32903-3116.	
They are protected by copyright. Set of labels may be obtained from ALI or its member companies.	
© 1992 by ALI, Inc. ALIWL101c	

<b>WARNING</b>	<b>WARNING</b>
	
Clear area if vehicle is in danger of falling.	Position vehicle with center of gravity midway between adapters.
<b>WARNING</b>	<b>WARNING</b>
	
Remain clear of lift when raising or lowering vehicle.	Avoid excessive rocking of vehicle while on lift.
<b>WARNING</b>	<b>WARNING</b>
	
Do not override self-closing lift controls.	Keep feet clear of lift while lowering.
The messages and pictographs shown are generic in nature and are meant to generally represent hazards common to all automotive lifts regardless of specific style.	
Funding for the development and validation of these labels was provided by the Automotive Lift Institute, PO Box 33116 Indialantic, FL 32903-3116.	
They are protected by copyright. Set of labels may be obtained from ALI or its member companies.	
© 1992 by ALI, Inc. ALIWL101w	

Ensure lift operators review safety and warning labels prior to operating lift.

## Safety and Operating Instructions

### Only authorized personnel are to operate lift

#### Read operating and safety procedures manual completely before operating lift.

- Properly maintain and inspect lift in accordance to owner's manual.
- Do not operate a lift that is damaged or in need of repair.
- Allow only authorized personnel in the lift bay.
- Stay clear of Lift when raising or lowering (NO RIDERS)
- Keep hands and feet away from pinch points at all times.
- Never override the Lift's operating and safety controls.
- If a vehicle is suspected of falling, clear area immediately.
- Do not rock vehicle while positioned on lift (except first 3" of rise when checking for stability).
- Always use safety jack stands when removing or installing heavy components.

#### Vehicle Loading

- Position vehicle for proper weight distribution (center of gravity should be midway between adapters).
- Swing arms under vehicle to allow adapters to contact the manufacturer's recommended pick up points.
- Use caution before lifting pickup trucks, suv's and other framed vehicles. The individual axle weight capacity should not exceed 1/2 of lift capacity.
- Make sure vehicle is neither front nor rear heavy.
- Make sure the lifting pads are in a proper and safe position to support the vehicle. (Ref: Lifting Points Guide and decal on Main side column for typical arm positioning)

#### Raising Lift

- Push Up switch to raise lift (make sure arm restraints engage or stop and slightly move arm to allow gear to mesh) until tires clear floor.
- Stop and check for secure contact on adapters and vehicle weight distribution. If secure raise to desired height.
- ALWAYS lower the lift into the nearest lock position by pressing the lower lever to relieve the hydraulic pressure and let the latch set right in a lock position.
- Never work under a lift that is not in the locked position.

#### Lowering Lift

- Clear all obstacles from under lift and vehicle and ensure only the lift operator is in the lift area.
- Stay clear of lift and raise the lift off the safety locks.
- Pull safety latch releases and press the lower lever to begin descent.
- Unload lift by first completely lowering lift, then swinging arms to drive-thru position before moving vehicle.

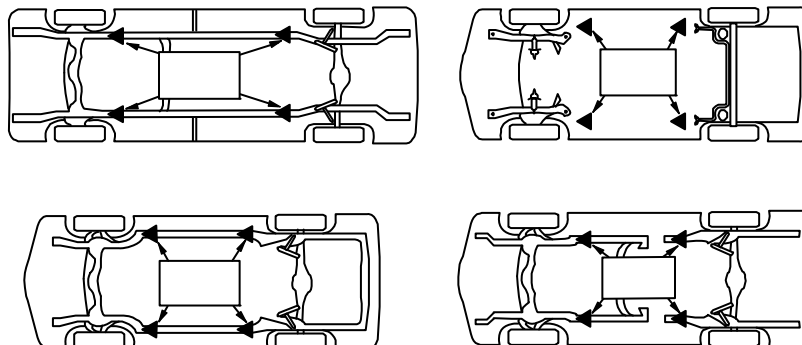

#### Lift Points Note:

Pro9F 9000 lbs. Floor Plate Lift

Refer to the manufacturer's specific vehicle lifting points. Some vehicles display these points on a label inside the right front door lock face or are identified by triangle shape marks on the vehicle's undercarriage, reference SAE J2184.

## **PREVENTIVE MAINTENANCE SCHEDULE**

The periodic Preventive Maintenance Schedule given is the suggested minimum requirements and minimum intervals; accumulated hours or monthly period, which ever comes sooner.

Periodic maintenance is to be performed on a **daily**, **weekly**, and **yearly** basis as given in the following paragraphs.

### **WARNING!!**

**Occupational Safety and Health Administration (OSHA) and the American National Standards Institute (ANSI) requires users to inspect lifting equipment at the start of every shift. These and other periodic inspections are the responsibility of the user.**

**Failure to perform the daily pre-operational check can result in expensive property damage, lost production time, serious personal injury, and even death. The safety latch system must be checked and working properly before the lift is put to use.**

**Failure to heed this warning can result in death or serious injury, or damage to equipment. If you hear a noise not associated with normal lift operation, or, if there is any indications of impending lift failure - CEASE OPERATION IMMEDIATELY! - Inspect, correct and/or replace parts as required.**

#### • **Daily Pre-Operation Check (8-Hours)**

1. Check safety lock audibly and visually while in operation
2. Check safety latches for free movement and full engagement with rack.
3. Check hydraulic connections, and hoses for leakage.
4. Check chain connections - bends, cracks-and loose links.
5. Check cable connections- bends, cracks-and looseness.
6. Check for frayed cables in both raised and lowered position.
7. Check snap rings at all rollers and sheaves.
8. Check bolts, nuts, and screws and tighten if needed.
9. Check wiring & switches for damage.
10. Keep base plate free of dirt, grease or any other corrosive substances.
11. Check floor for stress cracks near anchor bolts.
12. Check swing arm restraints.

#### • **Weekly Maintenance (every 40-Hours)**

1. Check anchor bolts torque to **80 ft-lbs** for the 3/4 in. anchor bolts. Do not use an impact wrench to tighten anchor bolts.
2. Check hydraulic oil level.
3. Check cylinder pulley assembly for free movement or excessive wear on cylinder yoke or pulley pin.
4. Check cable pulley for free movement and excessive wear.

- **Yearly Maintenance**

1. Lubricate chains
2. Grease rub blocks and column surface contacting rub blocks
3. Change the hydraulic fluid - good maintenance procedure makes it mandatory to keep hydraulic fluid clean. No hard fast rules can be established; - operating temperature, type of service, contamination levels, filtration, and chemical composition of fluid should be considered. If operating in dusty environment shorter interval may be required.

- **Special Maintenance Tasks**

**NOTE: The following items should only be performed by a trained maintenance expert:**

- Replacement of hydraulic hoses.
- Replacement of chains and rollers.
- Replacement of cables and sheaves.
- Replacement or rebuilding air and hydraulic cylinders as required.
- Replacement or rebuilding pumps / motors as required.
- Checking of hydraulic cylinder rod and rod end (threads) for deformation or damage.

## **CAUTION!!**

Relocating or changing components may cause problems. Each component in the system must be compatible; an undersized or restricted line will cause a drop in pressure. All valve, pump, and hose connections should be sealed and/or capped until just prior to use. Air hoses can be used to clean fittings and other components. However, the air supply must be filtered and dry to prevent contamination. Most important is cleanliness; Contamination is the most frequent cause of malfunction or failure of hydraulic equipment.

# **TROUBLESHOOTING**

The common problems that may be encountered and their probable causes are covered in the following paragraphs:

- **Motor Does Not Operate**

Failure of the motor to operate is normally caused by one of the following:

1. Breaker or fuse blown. Repair or replace.
2. Faulty wiring connections; call electrician.
3. Defective up button; call electrician for service.

- **Motor Functions but Lift Will Not Rise**

If the motor is functioning, but the lift will not rise, do the following in the order given:

1. A piece of trash might be under check valve. Push handle down and push the up button at the same time. Hold for 10-15 seconds. This should flush the system.
2. Check the clearance between the plunger valve of the lowering handle. There should be 1/16" clearance.
3. Remove the check valve cover and clean ball and seat.

## **WARNING!!**

**Failure to properly relieve pressure in the following step can cause injury to personnel. This lift uses ISO Grade 32 AW, 46 or other good grade non-detergent hydraulic oil at a high hydraulic pressure. Be familiar with its toxicological properties, precautionary measures to take, and first aid measures as stated in the Safety Summary before performing any maintenance with the hydraulic system.**

4. Oil level too low. Oil level should be just under the vent cap port when the lift is down. Relieve all hydraulic pressure and add oil as required.

- **Oil Blows out Breather of Power Unit**

If oil blows out of the breather of the power unit, take the following actions:

1. Oil reservoir overfilled. Relieve all pressure and siphon out hydraulic fluid until at a proper level
2. Lift lowered too quickly while under a heavy load. Lower the lift slowly under heavy loads.

- **Motor Hums and Will Not Run**

If the motor hums but fails to run, take the following actions:

1. Lift overloaded. Remove excessive weight from lift

**WARNING!!**

The voltages used in the lift can cause death or injury to personnel. In the following steps, make sure that a qualified electrician is used to perform maintenance

2. Faulty wiring..... Call electrician
3. Bad capacitor..... Call electrician
4. Low voltage..... Call electrician

- **Lift Jerks Going Up and Down**

1. If the lift jerks while going up and down, it is usually a sign of air in the hydraulic system. Raise lift all the way to top and return to floor. Repeat 4-6 times. **Do not let this overheat power unit.**

- **Oil Leaks**

Oil leak causes at the power unit and cylinders are normally caused by the following:

1. Power unit: if the power unit leaks hydraulic oil around the tank-mounting flange check the oil level in the tank. The level should be two inches below the flange of the tank. A screwdriver can be used as a "dipstick".
2. Cylinder - Piston Rod: the rod seal of the cylinder is out. Rebuild or replace the cylinder.
3. Cylinder - Vent: the piston seal of the cylinder is out. Rebuild or replace the cylinder.

- **Lift Makes Excessive Noise**

Excessive noise from the lift is normally caused by the following:

1. Column of the lift is dry and requires grease.
2. Cylinder pulley assembly or cable pulley assembly is not moving freely.
3. May have excessive wear on pins or cylinder yoke.

# ILLUSTRATED PARTS BREAKDOWN

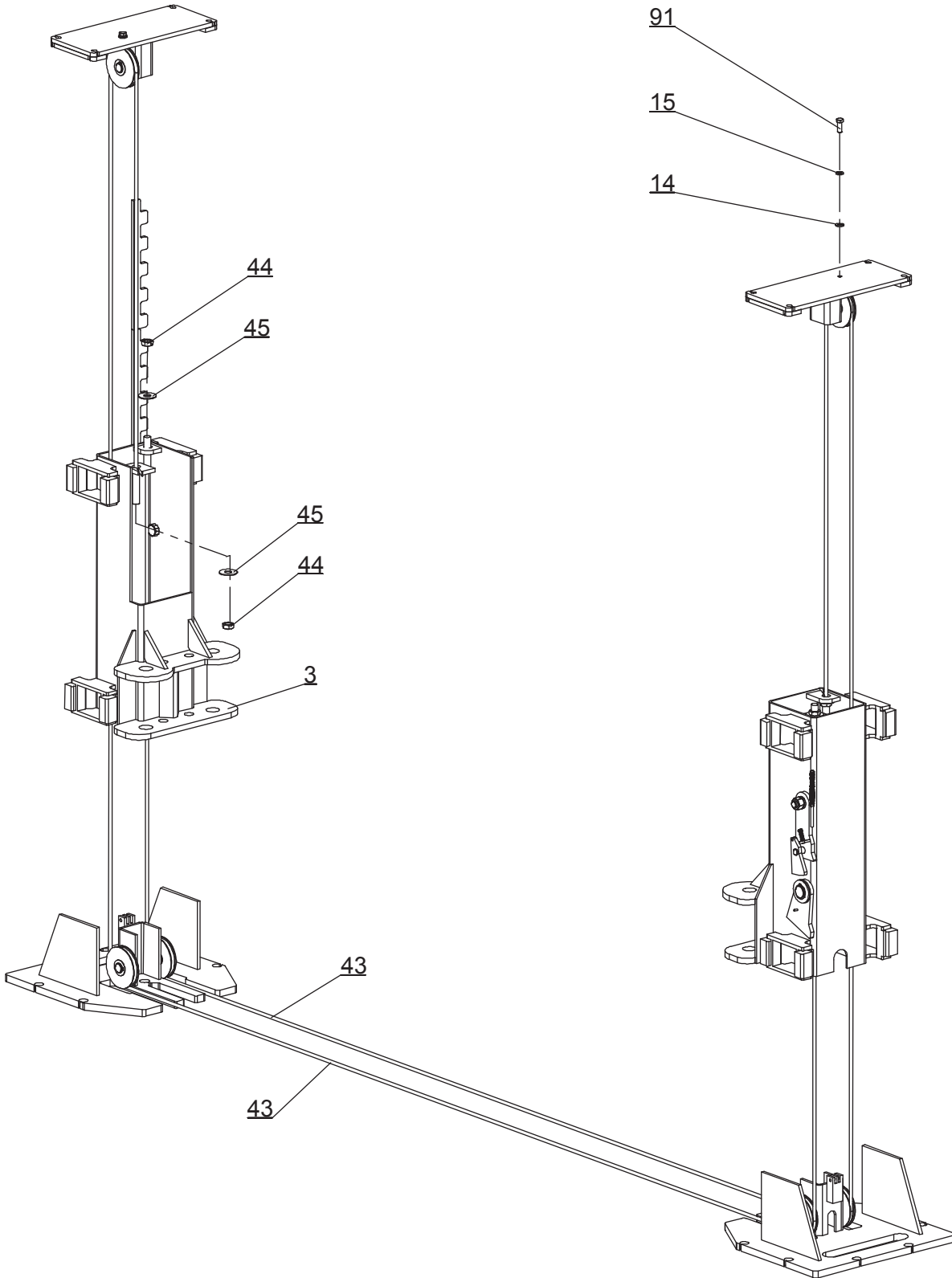

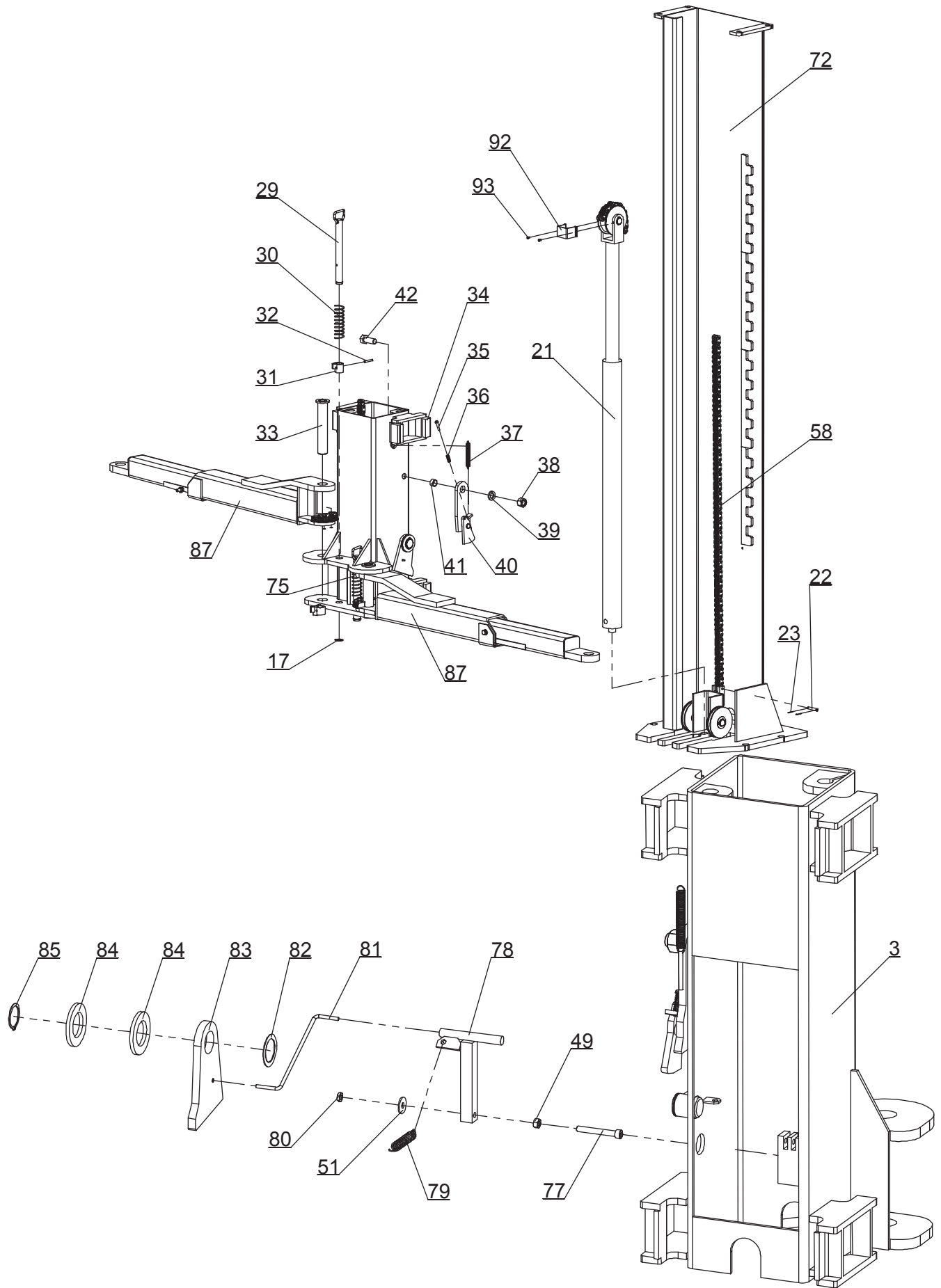



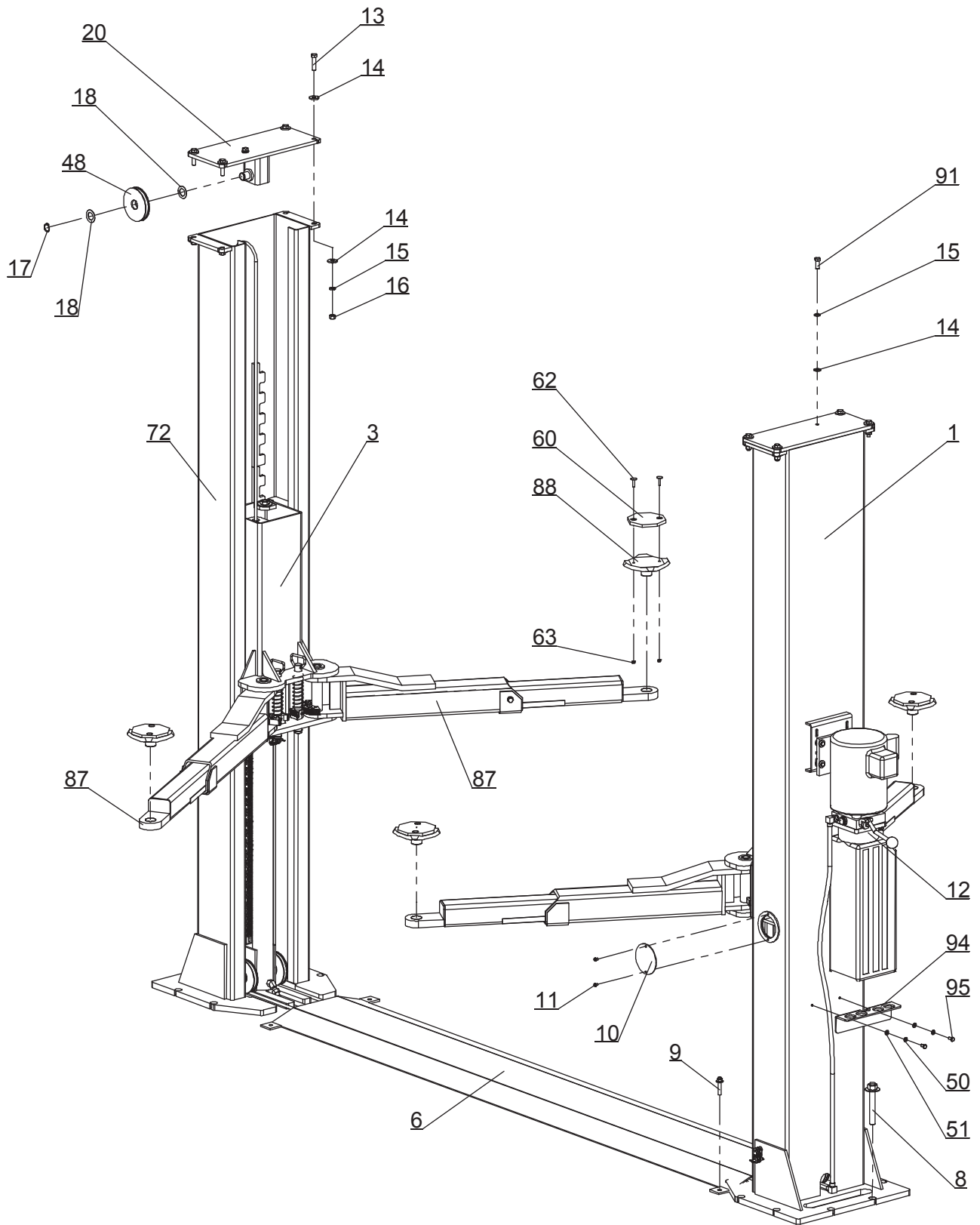

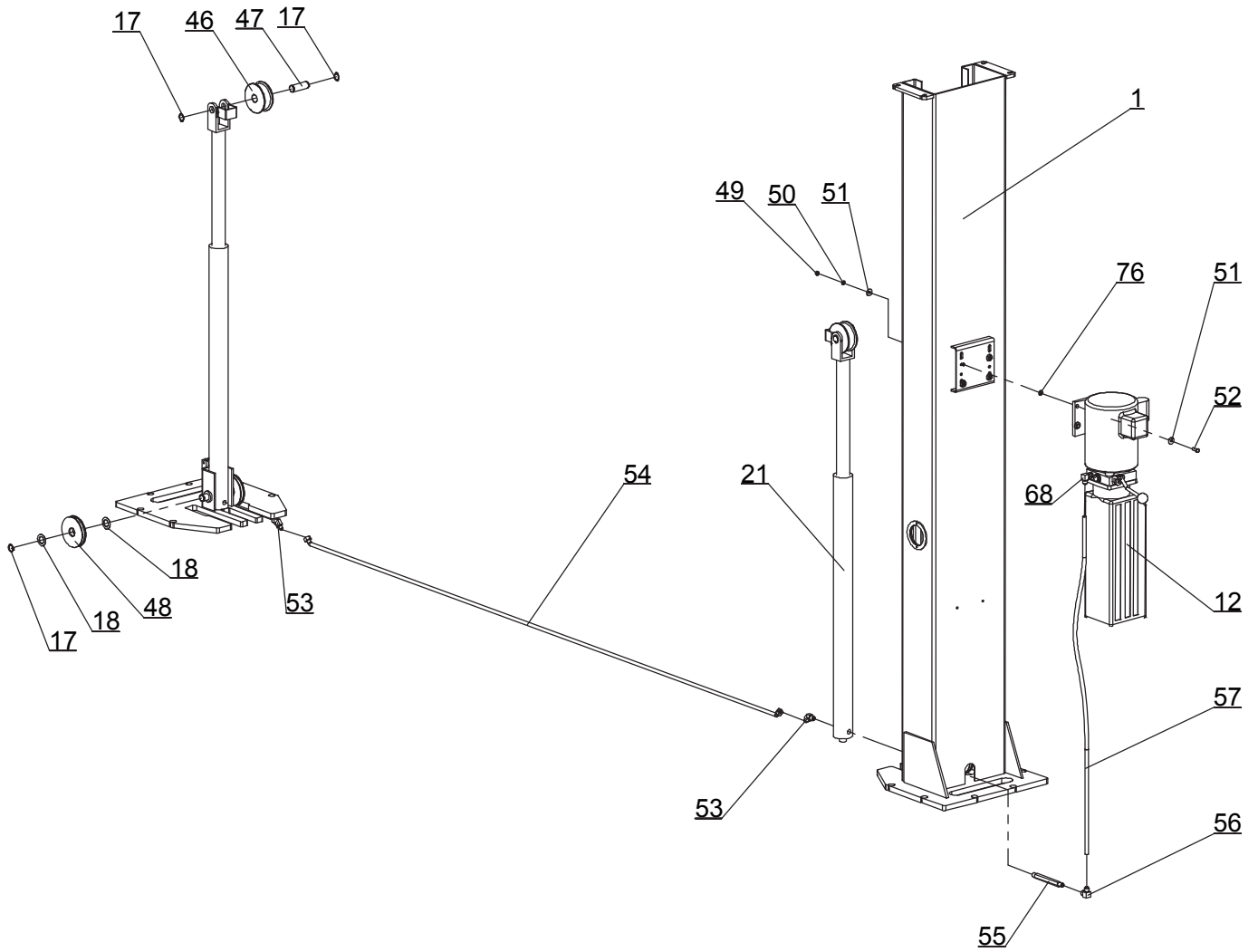

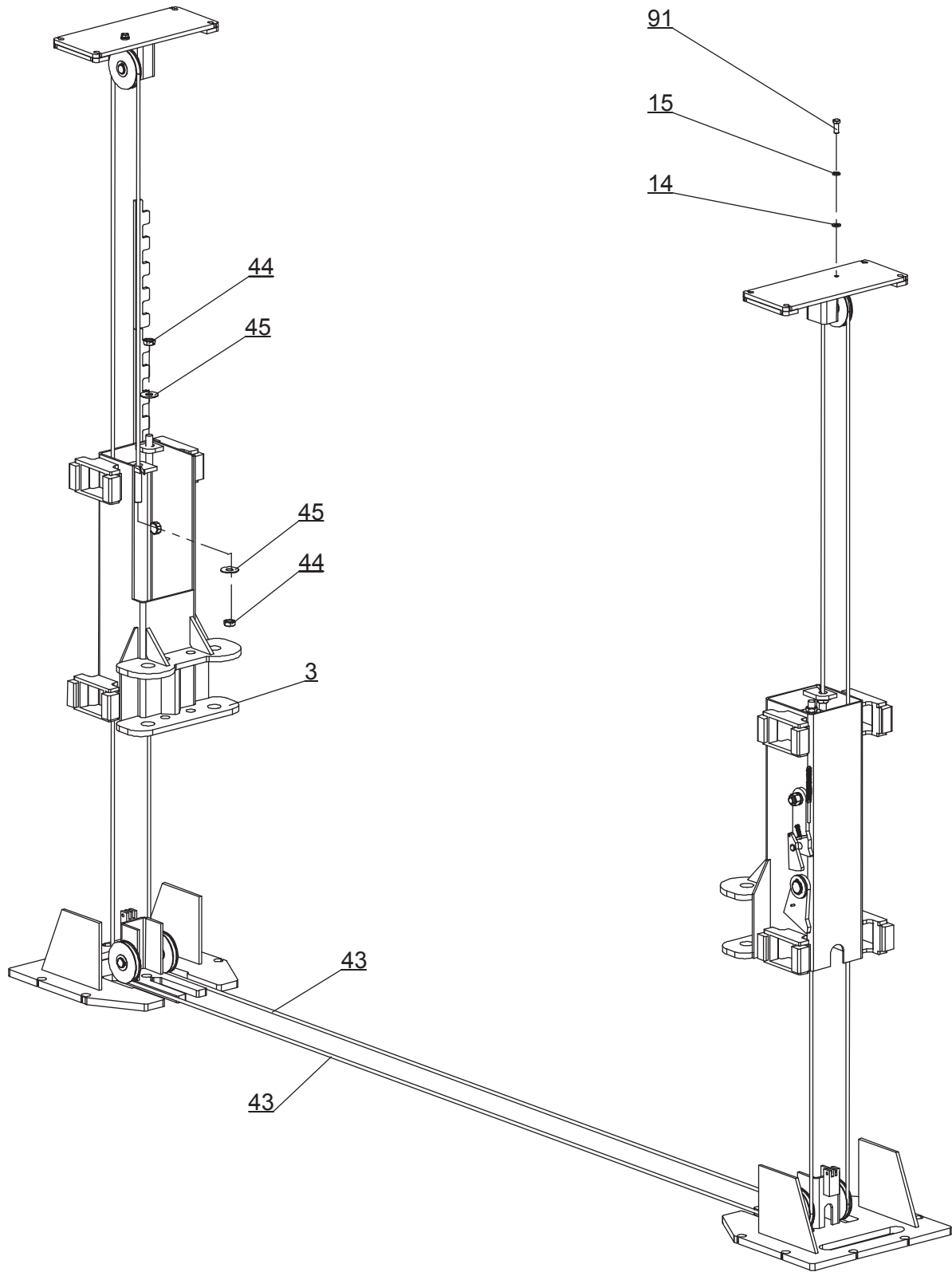

### Parts List

Items	Drawing	Description	QTY
1	GF-1000	Column Weldment	1
3	GF-2000	Carriage	2
6	GL-09-098	Runway Weldment	1
8	B14-3/4×150	Anchor Bolt 3/4"×150	12
9	B14-3/8×2.5	Anchor Bolt 3/8"×2.5"	4
10	30400-1013	Window Cover	2
11	B23-6×8	Cross Screw M6×8	4
12	P/U	Power Unit	1
13	B10-12×50	Hex Head Bolt M12×50	8
14	B41-12	Flat Washer Ø12	18
15	B40-12	Lock Washer Ø12	10
16	B30-12	Nut M12	8
17	B60-25	Snap Ring Ø25	14
18	30400-1005C	Flat Washer	12
20	GF-1500	Top Sheave Weldment	2
21	YG07-9100	Hydraulic Cylinder	2
22	30400-5023	Pin,Leaf Chain	4
23	B52-2×20	Cotter Pin Ø2×20	8
29	GF-2100	Shaft Pin	2
30	30500-5200-4	Spring	4
31	DP9-3003	Gear Rack	4
32	B51-6×40	Parallel Pin Ø6×40	4
33	30500-5300	Swing Arm Pin	4
34	30400-5020	Rubber Block	16
35	B28-6×35	Fastener Screw M6×35,NCHB	2
36	30400-5006-1	Spring	2
37	30400-5006-3	Spring	2
38	B31-20	Nut M20,Grade 8	2
39	B40-20	Lock Washer Ø20	2
40	30400-5006	Safety Block Organ	2
41	30400-5011	Bushing	2
42	B11-20×50	Hex Head Bolt M20×50,Grade 8.8	2
43	GF-4000	Steel Cable	2
44	B33-3/4-16	Nylon Lock Nut 3/4"-16	4
45	B41-20	Flat Washer Ø20	4
46	52080	Idler Wheel	2
47	30400-9012-01	Idler Wheel Shaft	2

48	52005	4.75"Cable Sheave	6
49	B30-8	Nut M8	6
50	B40-8	Lock Washer Ø8	8
51	B41-8	Flat Washer Ø8	14
52	B10-8×35	Hex Head Bolt M8×35	4
53	30400-9054(B)YZ	Bulkhead Fitting,45° Angle	2
54	1WB-06(GL-9000)	Hydraulic Hose	1
55	30500-9100G1	Bulkhead Fitting,Right Angle	1
56	30400-9052YZ	Inside And Outside Fitting,Right Angle	1
57	1WB-01(30400-9030YZ)	Hydraulic Hose	1
58	BL644×121P	Leaf Chain	2
60	52200-3	Rubber Board	4
62	B13-6×28	Strap Bolt M6×28	4
63	B30-6	Nut M6	4
68	30400-9053YZ(SW-002)	Fitting,Right Angle	1
72	GF-1100	Column Weldment	1
75	GF-2100DC	Shaft Pin	2
76	30400-1999	Shock Absorption Washer	4
77	ETPF-2007	Socket Head Screw	2
78	9B-4100	Chain Lock Weldment	2
79	ETPF-2004	Spring	2
80	B33-8	Nylon Lock Nut M8	2
81	GL-09-102	Connecting Rod Clevel	2
82	30400-5031	Washer	2
83	30400-5028	Chain Lock	2
84	B40-36	Flat Washer Ø36	4
85	B60-35	Snap Ring Ø35	2
87	GF-3000	Long Arm Weldment	4
88	GF-6100	Adapter weldment	4
91	B11-12×30	Hex Head Bolt M12×35	2
92	GF-1005	chain cover	2
93	B23-4×8	Cross Screw M4×8	4
94	GF-1004	PAD HT ADAPTER RACK	2
95	B11-8×15	Hex Head Bolt M8×15	4

**Notes:**

**Notes:**

## **Notes:**